

Tylan FC-2920/FM-3920 Mass Flow Controllers and Flowmeters

Provides superior gas flow control and measurement up to 200 slm (420 scfh)



Process Values

The Tylan FC2920 mass flow controllers and the Tylan FM3920 flowmeters accurately and reliably measure and control the mass flow rate of gases up to 200 slm (420 scfh) of nitrogen equivalents. The Tylan FC2921 offers a 15-pin D connector with optional 4-20 mA DC signals. The Tylan FM3920 and FM3921 flowmeters have the same specifications and dimensions as the Tylan FC2920 and Tylan FC2921 MFCs respectively. The Tylan FC2920 MFCs consist of a thermal gas flow sensor, adjustable bypass flow splitter, adjustable solenoid control valve and electronics.

Features

- Gas Flow to 200 slpm N₂
- Fast response to setpoint command
- Normally closed solenoid control valve
- Autozero circuit
- Optional 15 pin D connector with 4-20 mA DC signals
- All stainless steel

Product Features

Thermal Gas Flow Sensor

Bypass Flow splitter

Solenoid control valve

Product Benefits

The Tylan FC2920 measures gas flow rates using Tylan's patented temperature differential sensing device. The temperature difference of gas flowing past two heated, resistive temperature sensors is directly proportional to the mass flow rate of the gas. An insulated small diameter capillary is used in the sensing element which greatly reduces variations with attitude. This allows the Tylan FC2920 MFC to be mounted in any position.

The bypass flow splitter smooths the primary gas flow into the laminar flow region and produces sufficient pressure drop to divert a small portion of gas into the thermal sensor. The flow range is set by adjusting the length of the stainless steel mesh bypass.

The control mechanism is a normally closed proportional solenoid valve which is easily adjusted and provides fast response. Except for the dynamic plunger, all gas wetted metal surfaces are of 316L stainless steel. The plunger is 446 stainless steel.

Tylan FC-2920/FM-3920 MFCs and Flowmeters - Ordering Information

Performance

Full Scale (N2 equivalent)	30 slpm – 200 slpm
Turndown Ratio	25:1
Step Response Time	30-100 slpm, 3 sec 100-200 slpm, 6 sec
Accuracy	± 2.0% full scale
Linearity	± 0.5% full scale
Repeatability	± 0.2% full scale
Pressure Coefficient	0.00001% per bar, 0.007% per psi (typical)
Temperature Coefficient	0.05% per °C (zero and span)
Attitude Sensitivity	< 0.25% @ 90° C without autozero

Mechanical

Valve	Normally-closed solenoid
Materials	316L stainless steel, 420 ss, PFA Teflon
Leak Integrity	5 x 10 ⁻⁹ atm-cc per sec (He) inboard <4% full scale with Teflon poppet (normally-closed)
Weight	1.1 Kg (2.5 lb)

Electrical

Supply Voltage	± 12 VDC to ± 18 VDC
Supply Current	170 mA nominal (200 mA max @ ± 18 VDC)
Power Consumption	3.5 watts @ ± 15 volts
Input/Output Signal	0-5 VDC
Option(15pin D sub)	4-20mA DC
Supply Current	190 mA nominal (220 mA max @ ± 18 VDC)

Environmental

Operating Temperature	5 – 50° C (ambient and gas)
Humidity	0 – 95% RH, non-condensing
Maximum Inlet Pressure	11.5 bar (150 psig)
Differential Pressure	30-99 slpm 20-50 psid 100-150 slpm 30-60 psid 151-200 slpm 40-60 psid

Note: In accordance with SEMI Standard E12-91, Standard Temperature is 0° C and Standard Pressure is 760 mm Hg (14.7 psia).

Electrical Connection

	Card Edge	15Pin "D"	9Pin "D"		Card Edge	15Pin "D"	9Pin "D"
+ 15 VDC	4	5		Az INHIBIT	J	3	
COMMON	C	10		VALVE TEST (± 15 VDC)	D	12	
-15 VDC	F	6		VALVE OFF	L	15	
0-5 V Out	3	2		OVERRIDE			
COMMON	2	1		4-20 mA IN		7	
0-5 V IN	A	8		4-20mA OUT		4	
COMMON	8	9		CASE GND	1	14	
V REF	6	11		VALVE VOLTAGE (0-7 VDC)			
PRESS. IN	5	3					
Az STORE	K						

Consult our applications specialists with any questions. * Optional Kalrez and Viton are trademarks of DuPont Dow Elastomers, L.L.C. Swagelok is a trademark of Crawford Fitting Company. Teflon is a trademark of E. I. du Pont de Nemours and Company VCO and VCR are trademarks of Cajon Company

FC-2920/FM-3920 Ordering Information

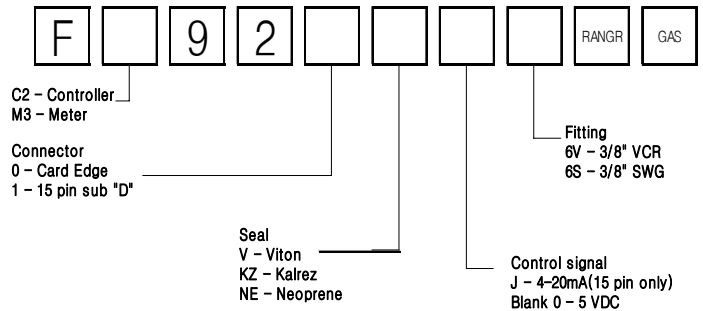

FC-2920/FM-3920 Dimensions

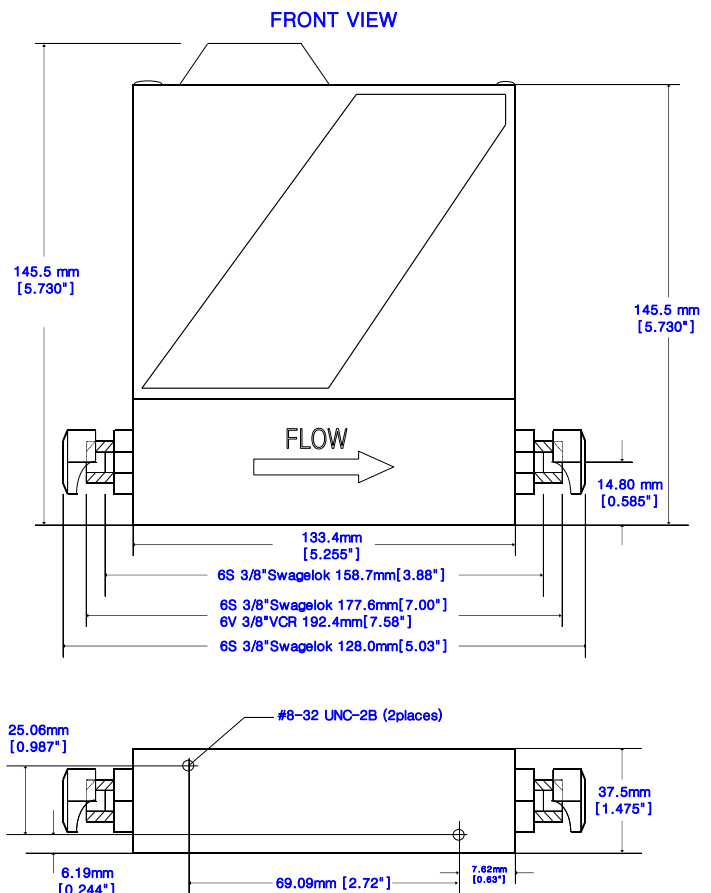

Gas Panel Drawing

